

The Ultimate Vector Dynamics Assignment

9701

1.

A 75 kg man stands on a scale while accelerating upwards in an elevator. If the scale reads 850 N, what is the magnitude of the acceleration of the elevator?

- A. 1.2 m/s²
- B. 1.5 m/s²**
- C. 9.8 m/s²
- D. 11 m/s²



$$F_N - F_g = ma$$

$$\frac{850 - mg}{m} = a$$

$$a = \frac{850 - 75(9.8)}{75}$$

2.

A 45 kg toboggan and rider decelerate on level snow at 0.53 m/s². What is the coefficient of friction between the toboggan and the snow?

- A. 0.012
- B. 0.054**
- C. 0.22
- D. 0.53

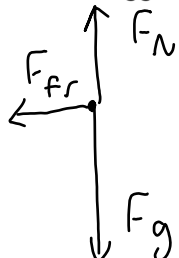

$$F_{fr} = ma$$

$$\mu F_N = ma$$

$$\mu mg = ma$$

$$\mu = \frac{a}{g} =$$

9706

3.

The 4.0 kg block shown accelerates across a frictionless horizontal table at 1.5 m/s².

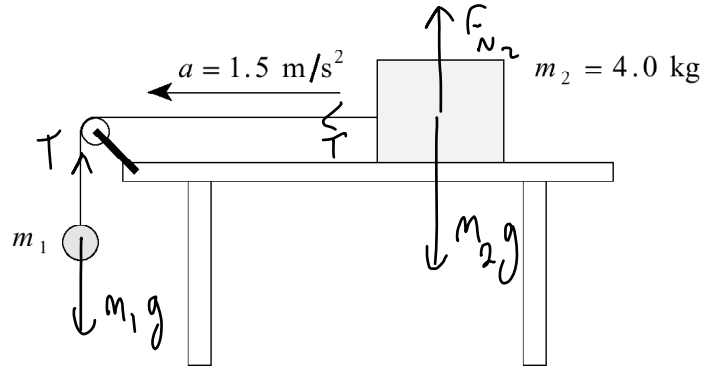

Find the mass of object m_1 .

- A. 0.61 kg
- B. 0.72 kg**
- C. 6.0 kg
- D. 26 kg

$$m_1 g - T + T = m_{\text{both}} a_{\text{both}}$$

$$m_1 g = (m_1 + m_2) a$$

$$m_1 g = m_1 a + m_2 a$$

$$m_1 g - m_1 a = m_2 a$$

$$m_1 (g - a) = m_2 a$$

$$m_1 = \frac{m_2 a}{g - a} = \frac{4(1.5)}{9.8 - 1.5}$$

4.

Which of the following is **not** a statement of one of Newton's laws of motion?

- A. For every action force, there is an equal and opposite reaction force.
- B. If no net force acts on an object, the object will remain at rest, or continue to move at a constant velocity.
- C.** The acceleration of freely falling objects is proportional to their mass.
- D. If a net force does act on an object, the object will accelerate in the direction of the net force.

5.

Three blocks have masses 1.0 kg, 7.0 kg and 5.0 kg as shown. The horizontal surface is frictionless.

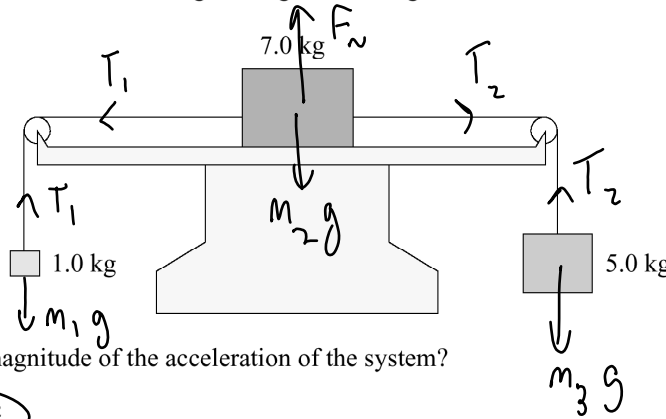

What is the magnitude of the acceleration of the system?

- A.** 3.0 m/s²
- B. 3.8 m/s²
- C. 6.5 m/s²
- D. 7.8 m/s²

$$\begin{aligned}
 m_3 g - m_1 g &= m_{\text{all}} a \\
 m_3 g - m_1 g &= (m_1 + m_2 + m_3) a \\
 a &= \frac{m_3 g - m_1 g}{m_1 + m_2 + m_3}
 \end{aligned}$$

6.

A 2.0 kg block is sliding down a 15° incline. The coefficient of friction is 0.62. At some position the block has a speed of 7.0 m/s.

need a!

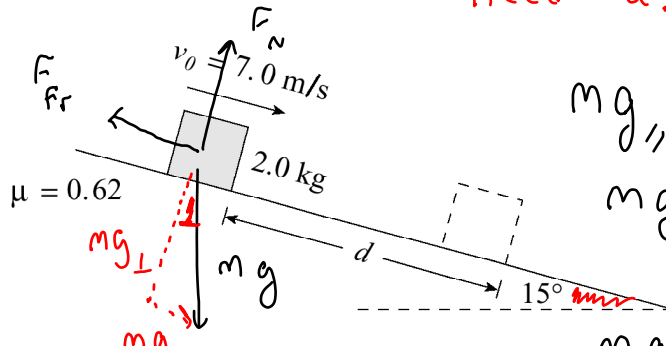

$$mg_{\parallel} - F_{fr} = ma$$

$$mg_{\parallel} - \mu F_N = ma$$

$$mg_{\parallel} - \mu mg_{\perp} = ma$$

$$mg \sin(15^\circ) - \mu mg \cos(15^\circ) = ma$$

What distance d will this block move before coming to rest?

- A. 2.5 m
- B. 4.0 m
- C. 4.2 m
- D.** 7.4 m

$a = -3.33$ (slowing down!)
 $v_f = 0$ $v_i = 7$ $d = ?$

$$d = \frac{v_f^2 - v_i^2}{2a} = \frac{0 - 7^2}{2(-3.3)} = 7.4 \text{ m}$$

7.

In the diagram shown, the tension in the cord connecting the hanging mass and cart is 43 N.

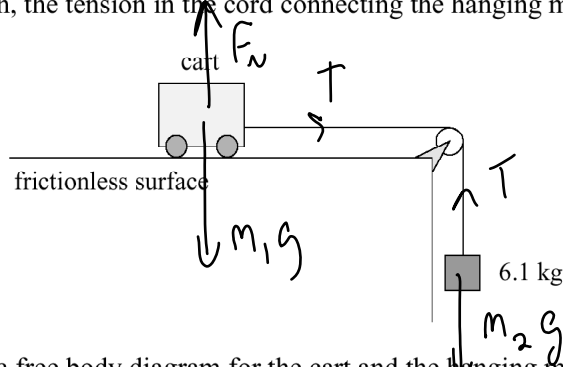

a) Draw and label a free body diagram for the cart and the hanging mass.

(2 marks)

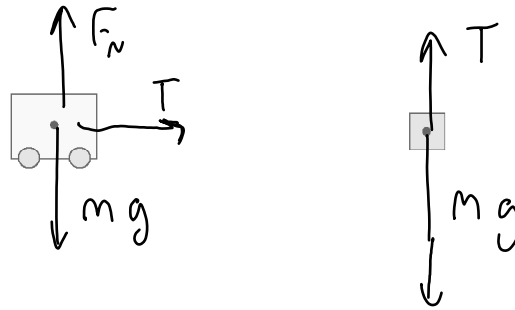

b) Determine the mass of the cart.

(5 marks)

look at m_2 first!

$$m_2 g - T = m_2 a$$

$$a = \frac{m_2 g - T}{m_2}$$

$$a = \frac{(6.1)(9.8) - 43}{6.1}$$

$$a = 2.75 \text{ m/s}^2$$

Now look at m_1

$$T = m_1 a$$

$$\frac{T}{a} = m_1$$

$$m_1 = \frac{43}{2.75} = 15.6 \text{ kg}$$

9801

8.

A student exerts a 120 N horizontal force on a 25 kg carton of apples, causing it to accelerate over level ground at 1.8 m/s^2 .

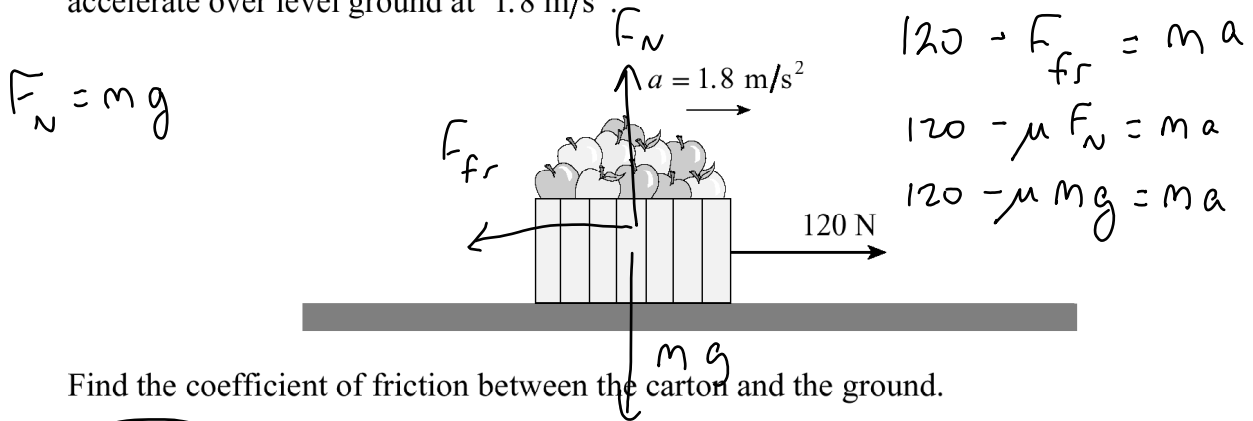

- A. 0.31
- B. 0.38
- C. 0.49
- D. 0.67

$$\mu mg = 120 - ma$$

$$\mu = \frac{120 - ma}{mg} = \frac{120 - 25(1.8)}{25(9.8)} = 0.31$$

9.

A net force F acts on an object of mass m , causing it to accelerate at 4.0 m/s^2 . If the same net force F acts on an object of mass $2m$, its acceleration will be

- A. 1.0 m/s^2
- B. 2.0 m/s^2
- C. 4.0 m/s^2
- D. 8.0 m/s^2

$$F = ma$$

double the mass,
and you cut the accel.
in half

10.

A student drags a 7.0 kg carton of apples across the floor by exerting a 45 N force in the direction shown. The coefficient of friction between the carton and the floor is 0.52.

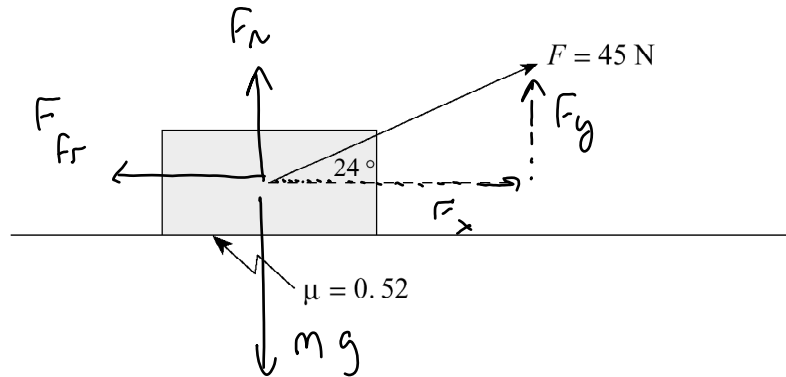

a) What is the magnitude of the normal force acting on the carton?

(2 marks)

$$mg = F_N + F_y$$

$$F_N = mg - F_y = mg - 45 \sin(24) = 50.3 \text{ N}$$

b) What friction force acts on the carton?

(2 marks)

$$F_{fr} = \mu F_N = (0.52)(50.3) = 26.2 \text{ N}$$

c) What is the acceleration of the carton?

(3 marks)

$$F_x - F_{fr} = ma$$

$$\frac{45 \cos(24) - 26.2}{7} = a \quad a = 2.13 \text{ m/s}^2$$

9806

11.

A 72 kg skydiver drops from a helicopter and is accelerating downwards at 8.6 m/s^2 . Find the friction force acting on him.

- A. 86 N
- B. 620 N
- C. 710 N
- D. 1300 N



$$mg - F_{\text{drag}} = ma$$

$$F_{\text{drag}} = mg - ma = (72)(9.8) - 72(8.6)$$

12.

The diagram shows two objects connected by a light string over a frictionless pulley. Object m_2 is on a frictionless horizontal table. The tension in the string is 24 N.

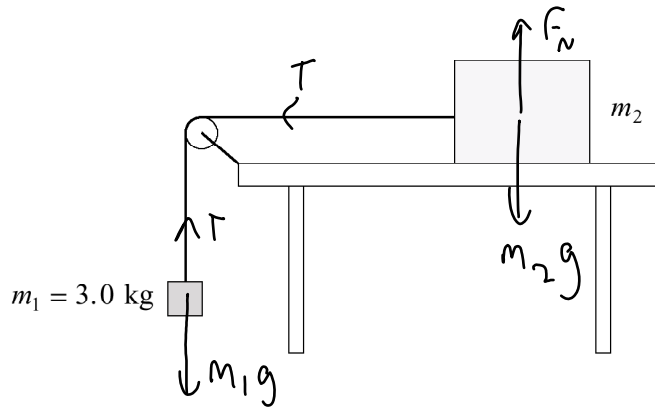

a) Find the acceleration of the system.

(4 marks)

look at m_1

$$m_1 g - T = m_1 a$$
$$a = \frac{m_1 g - T}{m_1} = \frac{3(9.8) - 24}{3} = 1.8 \text{ m/s}^2$$

b) Find the mass of m_2 .

(3 marks)

$$T = m_2 a$$
$$m_2 = \frac{T}{a} = \frac{24}{1.8} = 13.3 \text{ kg}$$

9808

13.

A girl applies a 140 N force to a 35 kg bale of hay at an angle of 28° above horizontal. The friction force acting on the bale is 55 N. What will be the horizontal acceleration of the bale?

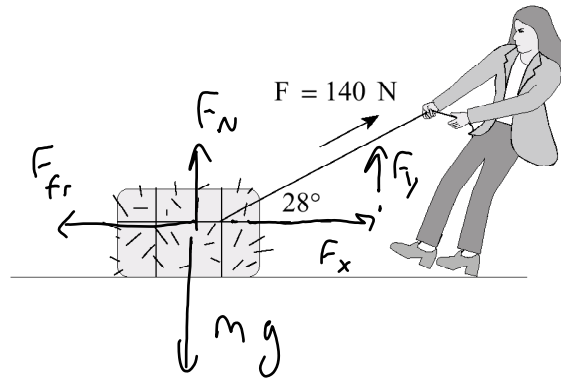

$$F_x - F_{fr} = ma$$

$$140 \cos 28 - F_{fr} = ma$$

$$\frac{140 \cos 28 - 55}{m} = a$$

$$a = 1.96$$

- A. 0.31 m/s^2
- B. 2.0 m/s^2
- C. 2.4 m/s^2
- D. 2.6 m/s^2

14.

A 5.0 kg concrete block accelerates down a 34° slope at 4.2 m/s^2 . Find the coefficient of friction between the block and the slope.

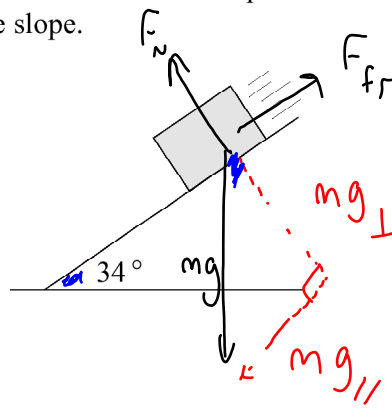

- A. 0.13
- B. 0.16
- C. 0.43
- D. 0.67

$$mg_{\parallel} - F_{fr} = ma$$

$$mg_{\parallel} - \mu F_N = ma$$

$$mg_{\parallel} - \mu mg_{\perp} = ma$$

$$g \sin 34 - \mu g \cos 34 = a$$

$$g \sin 34 - a = \mu g \cos 34$$

$$\mu = \frac{g \sin 34 - a}{g \cos 34}$$

$$\mu = \frac{(9.8) \sin 34 - 4.2}{9.8 \cos 34}$$

9901

15.

A block is on a frictionless incline.

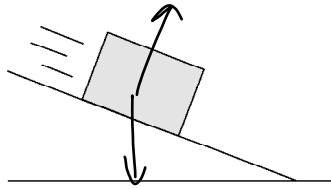

Which of the following is a correct free body diagram for the block?

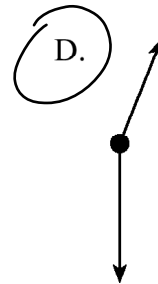
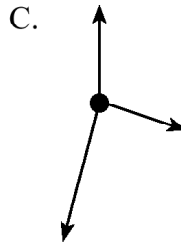
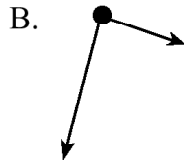
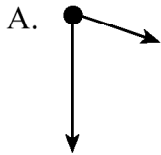

16.

A cart on a frictionless surface is attached to a hanging mass of 8.2 kg.

Use m_2 to find T ,
then use T to
find m

$$m_2 g - T = m_2 a$$

$$T = m_2 g - m_2 a = 51.66 \text{ N}$$

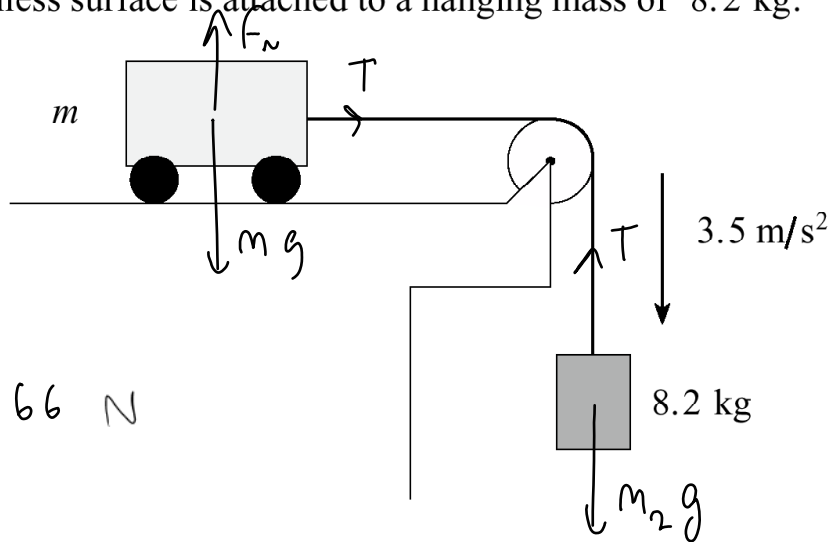

If this system accelerates at 3.5 m/s^2 , what is the mass m of the cart?

A. 6.0 kg

B. 15 kg

C. 23 kg

D. 31 kg

$$T = m a$$

$$\frac{T}{a} = m = \frac{51.66}{3.5} = 14.7 \text{ kg}$$

17.

Two objects are connected as shown. The 12 kg cart is on a frictionless 42° incline while the 15 kg block is on a horizontal surface having a coefficient of friction $\mu = 0.23$.

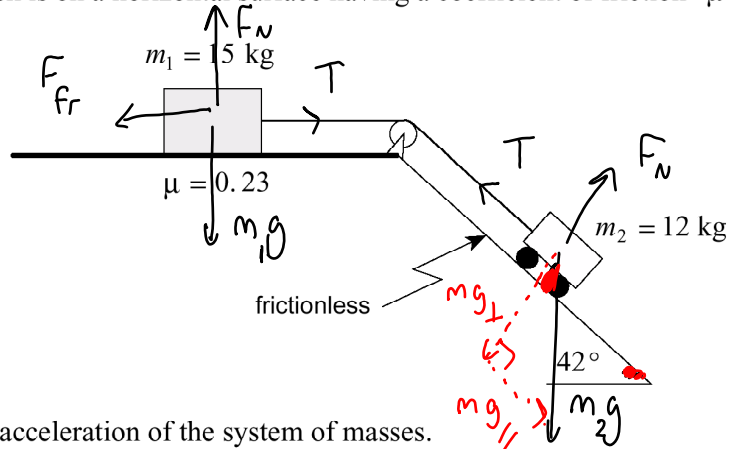

Determine the acceleration of the system of masses.

(7 marks)

$$m_1 g_{\perp} - T + T - F_{fr} = m_{\text{both}} a_{\text{both}}$$

$$m_2 g \sin 42 - \mu F_{N_1} = m_{\text{both}} a_{\text{both}}$$

$$m_2 g \sin 42 - \mu m_1 g = a$$

$$a = \frac{m_{\text{both}} (12(9.8) \sin 42 - (0.23)(15)(9.8))}{12 + 15}$$

$$a = 1.66 \text{ m/s}^2$$

9906

18.

A 15 kg block on a horizontal surface has a 100 N force acting on it as shown.

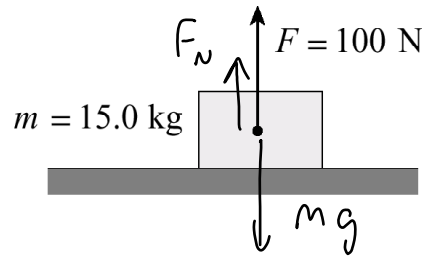

What is the normal force?

A. 47 N

B. 100 N

C. 147 N

D. 247 N

$$mg = F_N + F$$

$$F_N = mg - F = (15)(9.8) - 100 = 47 \text{ N}$$

19.

A 15 kg cart is attached to a hanging 25 kg mass. Friction is negligible.

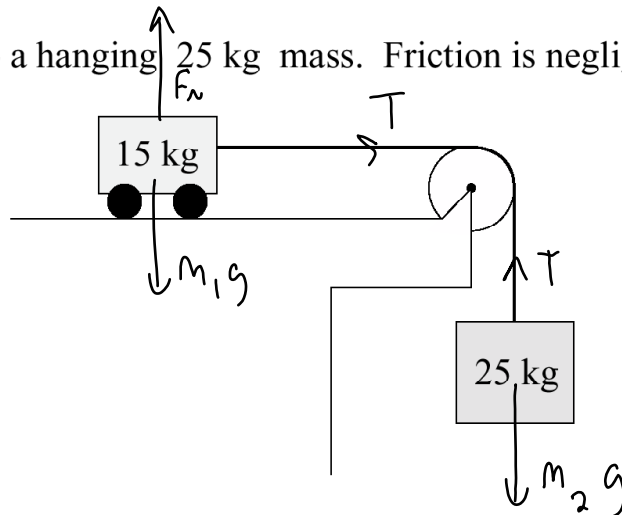

What is the acceleration of the 15 kg cart?

A. 2.5 m/s²

B. 6.1 m/s²

C. 6.5 m/s²

D. 16 m/s²

$$m_2 g - T + T = m_{\text{both}} a_{\text{both}}$$

$$\frac{m_2 g}{m_1 + m_2} = a$$

$$a = \frac{25(9.8)}{15 + 25} = 6.1 \text{ m/s}^2$$

20.

A 5 500 kg helicopter is travelling at constant speed in level flight.

$$\therefore F_{\text{net}} = 0$$

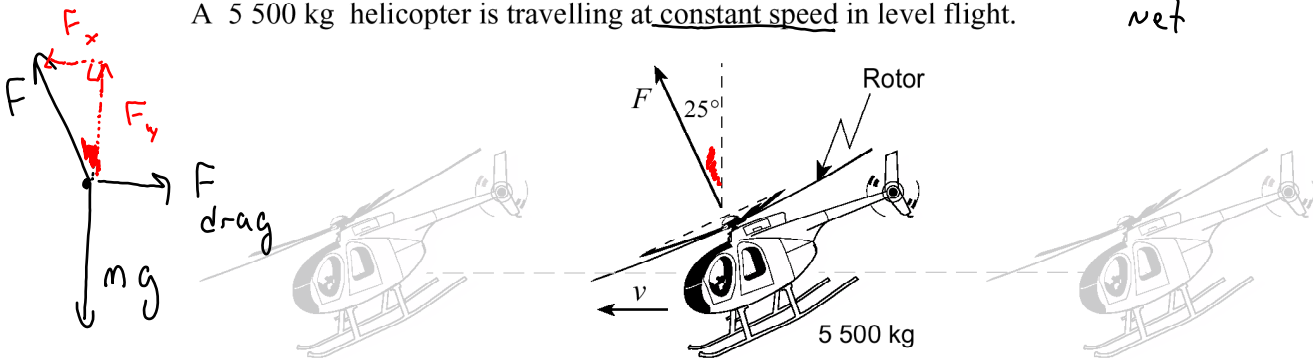

What is the force F provided by the rotor?

- A. 4.9×10^4 N
- B. 5.4×10^4 N
- C. 5.9×10^4 N
- D. 1.2×10^5 N

$$\cos 25 = \frac{F_y}{F} \quad F_y = mg$$

$$F = \frac{F_y}{\cos 25} = \frac{mg}{\cos 25} = 5.9 \times 10^4 \text{ N}$$

21.

A 15 kg block has a constant acceleration of 2.2 m/s^2 down a 30° incline.

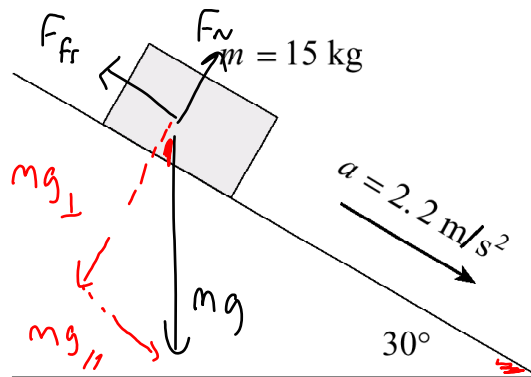

What is the magnitude of the friction force on the block?

- A. 33 N
- B. 41 N
- C. 74 N
- D. 130 N

$$mg_{\parallel} - F_{fr} = ma$$

$$mg_{\parallel} - ma = F_{fr}$$

$$mg \sin 30 - ma = F_{fr}$$

9908

22.

Which of the following graphs shows the relationship between acceleration and net force?

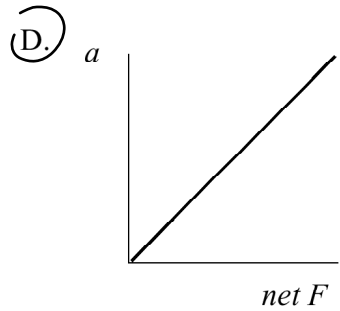
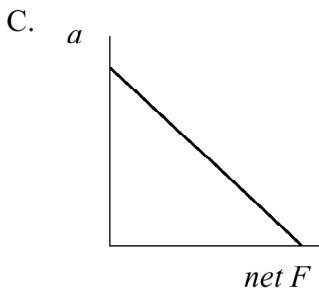
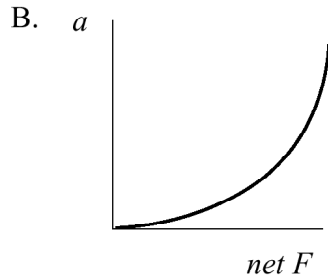
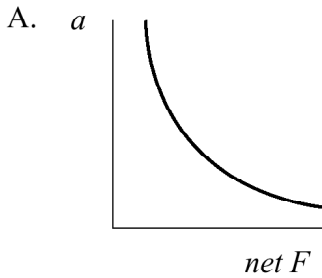

well...

$$F = ma$$

$$\frac{F}{a} = m$$

slope of graph is constant, since mass doesn't change

23.

A 12 kg cart on a 23° frictionless incline is connected to a wall as shown.

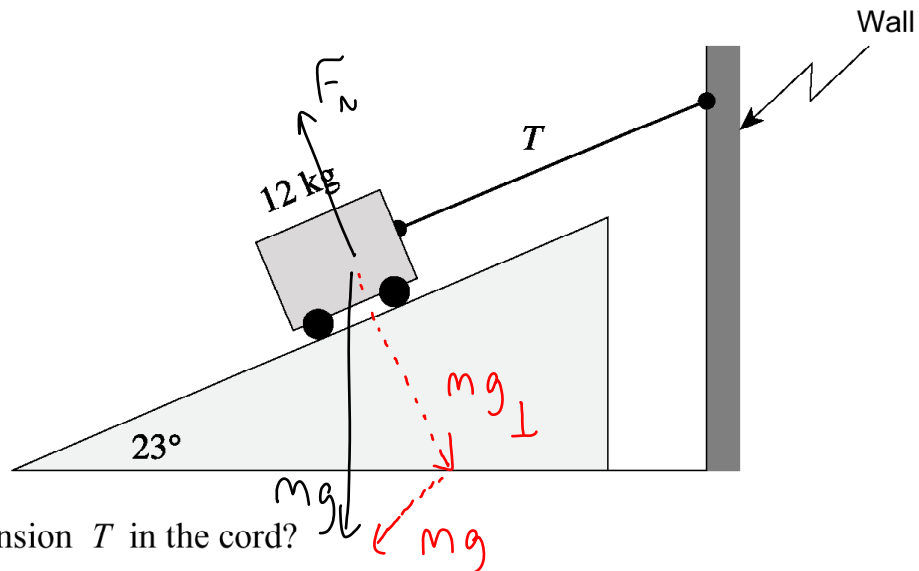

What is the tension T in the cord?

- A. 46 N
- B. 50 N
- C. 110 N
- D. 120 N

$$mg_{\parallel} - T = 0$$

$$mg_{\parallel} = T$$

$$mg \sin 23 = T$$

24.

An 18 kg cart is connected to a 12 kg hanging block as shown. (Ignore friction.)

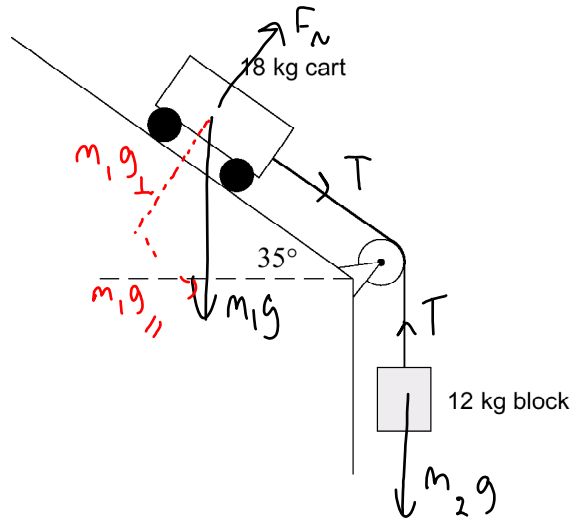

a) Draw and label a free body diagram for the 18 kg cart. (2 marks)



b) What is the magnitude of the acceleration of the cart? (5 marks)

$$m_2 g - T + T + m_1 g_{\parallel} = m_{\text{both}} a$$

$$\frac{m_2 g + m_1 g \sin 35}{m_1 + m_2} = a$$

$$\frac{(12)(9.8) + 18(9.8) \sin 35}{30} = a \quad a = 7.3 \text{ m/s}^2$$

0001

25.

A block of mass m remains at rest on an incline as shown in the diagram.

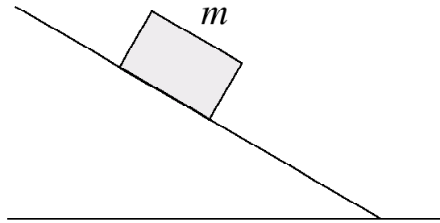

The force acting up the ramp on this block is

- A. 0.
- B. mg .
- C. less than mg .
- D. more than mg .

26.

Two masses are connected by a light string over a frictionless massless pulley. There is a coefficient of friction of 0.27 between mass m_1 and the horizontal surface.

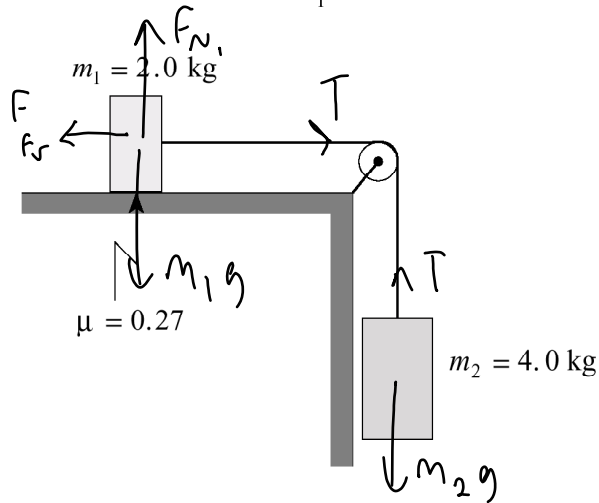

a) Draw and label a free body diagram showing the forces acting on mass m_1 .

(2 marks)

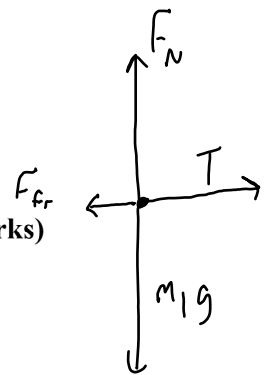

b) Find the acceleration of mass m_2 .

(5 marks)

$$m_2 g - T + T - F_{fr} = m_{\text{both}} a_{\text{both}}$$
$$\frac{4(9.8)}{m_1 + m_2} - \mu F_{N_1} = a \rightarrow a = \frac{4(9.8) - .27(2)(9.8)}{6}$$
$$a = 5.7 \text{ m/s}^2$$

0006

27.

A constant net force acting on an object results in the object having a constant

- A. velocity.
- B. momentum.
- C. acceleration.
- D. kinetic energy.

28.

A curling rock is travelling to the right across the ice as shown in the diagram.

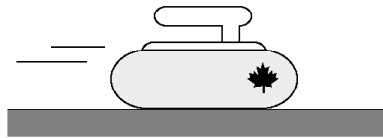

Which of the following best represents the forces acting on the curling rock?

- A.
- B.
- C.
- D.

0008

29.

An 810 kg dragster is being decelerated by a parachute at 2.5 m/s^2 as shown in the diagram.

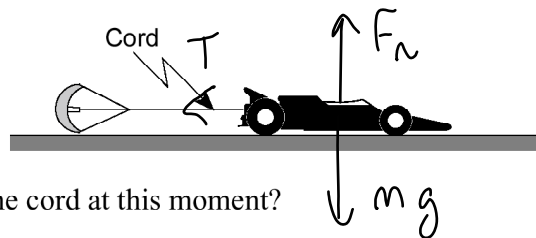

What is the tension in the cord at this moment?

- A. 0 N
- B. $2.0 \times 10^3 \text{ N}$
- C. $5.9 \times 10^3 \text{ N}$
- D. $7.9 \times 10^3 \text{ N}$

$$T = ma$$

$$T = (810)(2.5) = 2.0 \times 10^3 \text{ N}$$

30.

The system of blocks on a frictionless surface in the diagram below is accelerating at 2.0 m/s^2 .

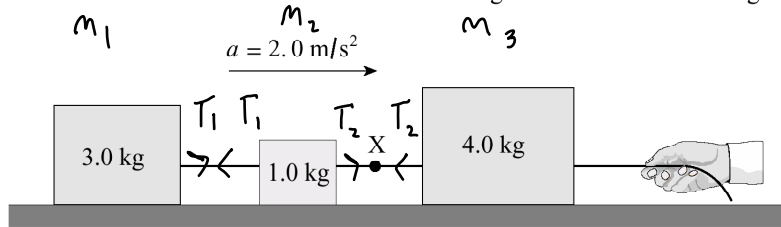

We want T_2
look at m_1 and m_2

What is the tension in the cord at X?

- A. 2.0 N
- B. 6.0 N
- C. 8.0 N
- D. 16 N

$$T_2 - T_1 + T_1 = m \text{ both } a \text{ both}$$

$$T_2 = (3 + 1)(2) = 8.0 \text{ N}$$

31.

A 5.0 kg block remains stationary on an inclined surface.

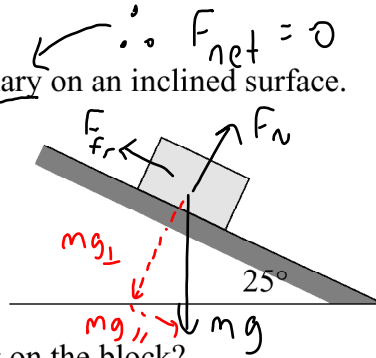

What is the friction force acting on the block?

- A. 21 N
- B. 23 N
- C. 44 N
- D. 49 N

$$F_{fr} - mg_{\parallel} = 0$$

$$F_{fr} = mg_{\parallel}$$

$$F_{fr} = mg \sin 25 = 5(9.8) \sin(25) = 20.7$$

0101

32.

An object is sliding down an inclined plane at a constant speed.

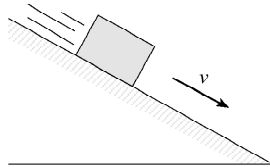

Which of the following represents the free-body diagram for the object?

- A.
- B.
- C.
- D.

33.

A 45 kg woman is standing in an elevator that is accelerating downwards at 2.0 m/s^2 . What force (normal force) does the elevator floor exert on the woman's feet during this acceleration?

- A. 90 N
- B. 350 N**
- C. 440 N
- D. 530 N



$$mg - F_N = ma$$

$$mg - ma = F_N$$

$$F_N = 351 \text{ N}$$

34.

A 15 kg block is pushed up a 35° incline. A friction force of 110 N exists between the block and the incline.

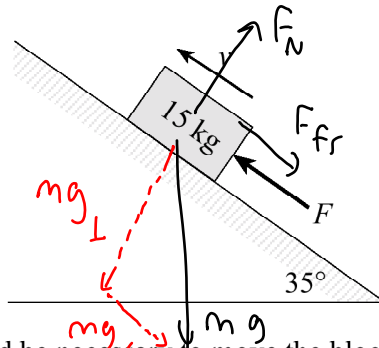

What minimum force F , would be necessary to move the block up the incline at a constant speed? $a = 0$

- A. 26 N
- B. 84 N
- C. 150 N
- D. 190 N**

$$F - F_{fr} - mg_{\parallel} = 0$$

$$F = F_{fr} + mg_{\parallel}$$

$$F = 110 + mg \sin 35^\circ$$

$$F = 194 \text{ N}$$

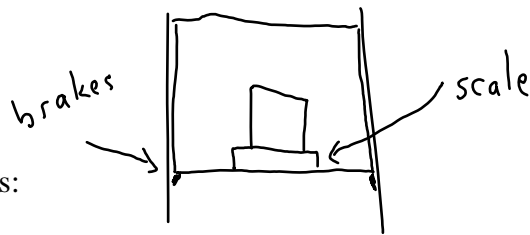

Scholarship Questions:

9401

35.

1. A 32.0 kg box is placed on a scale in an elevator. The total mass of the elevator plus contents is 725 kg. Suddenly, the supporting cable breaks and the elevator accelerates downwards, restricted only by emergency brakes which drag along the walls of the shaft. While the elevator is falling, the scale reads 210 N.

- a) Draw a free body diagram in the space below showing the forces acting **on the box** while the elevator is accelerating downwards. (2 marks)



- b) What is the acceleration of the elevator? (4 marks)

it will be the same as the box

$$mg - F_N = ma$$

$$\frac{mg - F_N}{m} = a \Rightarrow a = \frac{(32)(9.8) - 210}{32}$$

$$a = 3.2 \text{ m/s}^2$$

- c) What is the magnitude of the frictional force of the brakes against the walls of the shaft? (4 marks)

FBD of elevator



$$mg - F_{fr} = ma$$

$$F_{fr} = mg - ma = (725)(9.8) - (725)(3.2)$$

$$F_{fr} = 4.8 \times 10^3 \text{ N}$$

9406

36.

A hanging 3.0 kg mass is attached to an 8.0 kg block on a ramp inclined at 30° to the horizontal. The coefficient of friction between the 8.0 kg block and the ramp is 0.26 and the pulley is frictionless.

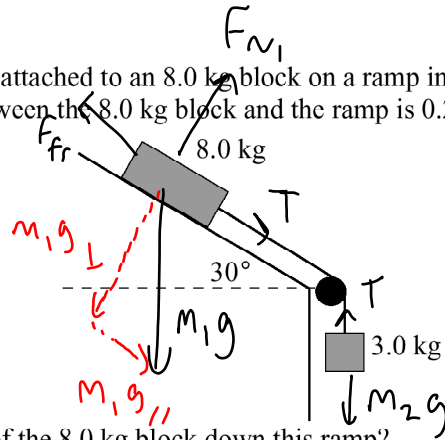

What is the acceleration of the 8.0 kg block down this ramp?

(10 marks)

$$M_2g - T + T + M_1g_{\parallel} - F_{fr} = M_{\text{both}} a_{\text{both}}$$

$$M_2g + M_1g_{\parallel} - \mu F_N = M_{\text{both}} a$$

$$M_2g + M_1g \sin 30 - \mu M_1g_{\perp} = M_{\text{both}} a$$

$$M_2g + M_1g \sin 30 - \mu M_1g \cos 30 = a$$

$$M_1 + M_2$$

$$\frac{3(9.8) + 8(9.8) \sin 30 - (0.26)(8)(9.8) \cos 30}{11} = a$$

$$a = 4.6 \text{ m/s}^2$$

9501

37.

1. A rocket accelerates at 25 m/s^2 from rest on a frictionless inclined surface. The rocket stops firing at the instant it leaves the incline.

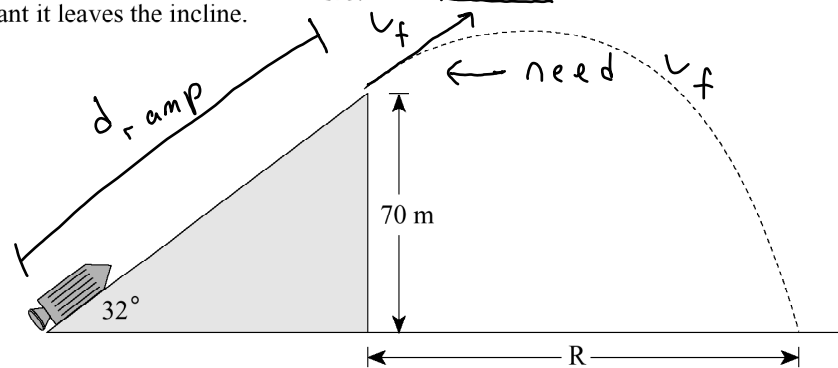

$$d_{\text{ramp}} = \frac{70}{\sin 32} = 132.1 \text{ m}$$

$$a = 25$$

$$v_0 = 0$$

$$v_f = ?$$

If air resistance is negligible, what is the distance R to the point of impact?

(12 marks)

$$v_f^2 = v_i^2 + 2ad$$

$$v_f = \sqrt{0 + 2(25)(132.1)} = 81.3 \text{ m/s}$$

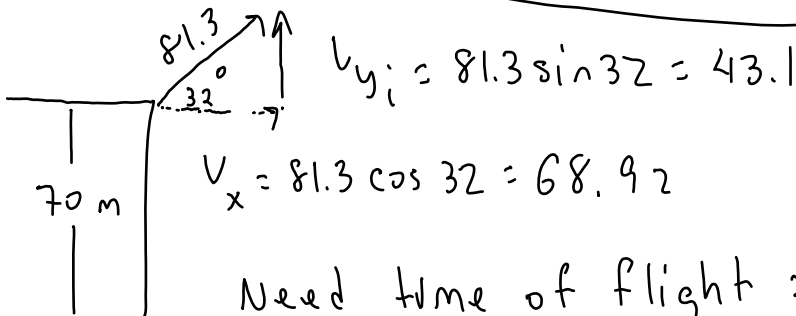

$$v_{y_i} = 81.3 \sin 32 = 43.1$$

$$v_x = 81.3 \cos 32 = 68.92$$

Need time of flight: solve vertically

$$d_y = v_{y_i} t + \frac{1}{2} a t^2$$

$$-70 = 43.1 t - 4.9 t^2$$

$$4.9 t^2 - 43.1 t - 70 = 0 \quad \text{use quad. form.}$$

$$\boxed{t = 10.2} \quad -1.4$$

$$\text{Now, } d_x = v_x t + \frac{1}{2} a_x t^2$$

$$d_x = (68.92)(10.2) = 703 \text{ m}$$

38.

The apparatus shown in the diagram below consists of a box of masses connected by a light string to a hanger. The box is moving up the incline at a constant speed. $\leftarrow a = 0$

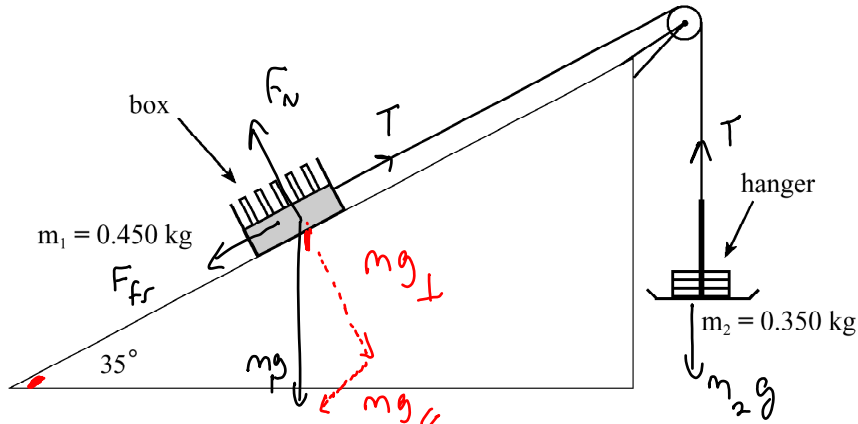

a) What is the coefficient of friction between the box and the incline?

(5 marks)

$$m_2 g + T - T - m_1 g_{\parallel} - F_{fr} = 0$$

$$m_2 g - m_1 g \sin 35 - \mu F_N = 0$$

$$m_2 g - m_1 g \sin 35 - \mu m_1 g_{\perp} = 0$$

$$m_2 g - m_1 g \sin 35 = \mu m_1 g_{\perp}$$

$$\mu = \frac{m_2 g - m_1 g \sin 35}{m_1 g \cos 35} = 0.249$$

b) If 0.150 kg of mass is transferred from the box to the hanger, what is the acceleration of the system?

(7 marks)

$$m_2 = .5$$

$$m_1 = .3$$

$$m_2 g - m_1 g_{\parallel} - F_{fr} = m_{\text{both}} a$$

$$m_2 g - m_1 g \sin 35 - \mu F_N = m_{\text{both}} a$$

$$m_2 g - m_1 g \sin 35 - \mu m_1 g_{\perp} = m_{\text{both}} a$$

$$m_2 g - m_1 g \sin 35 - \mu m_1 g \cos 35 = a$$

$$m_{\text{both}}$$

$$a = \frac{(.5)(9.8) - (.3)(9.8) \sin 35 - (.249)(.3)(9.8) \cos 35}{.8}$$

$$a = 3.27 \text{ m/s}^2$$

9506

39.

Two masses are connected by a light string which passes over a frictionless pulley as shown. The coefficient of friction between the 2.5 kg mass and the surface is 0.33.

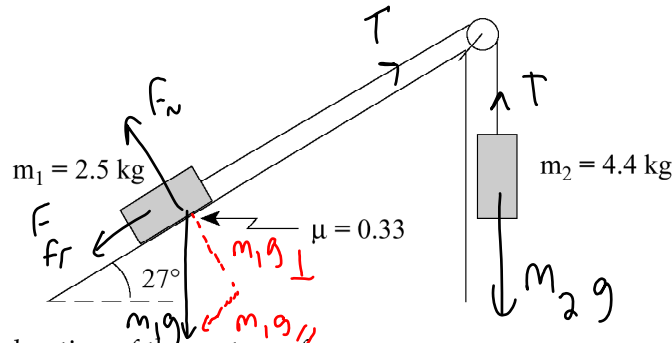

a) Find the acceleration of the system of masses.

(7 marks)

$$m_2 g - T + T - m_1 g_{\parallel} - F_{fr} = m_{\text{both}} a$$

$$m_2 g - m_1 g_{\parallel} - \mu F_N = m_{\text{both}} a$$

$$m_2 g - m_1 g_{\parallel} - \mu m_1 g_{\perp} = m_{\text{both}} a$$

$$\frac{m_2 g - m_1 g \sin 27 - \mu m_1 g \cos 27}{2.5 + 4.4} = a \quad a = 3.6 \text{ m/s}^2$$

b) Find the tension in the string.

(5 marks)

Look at mass 2

$$m_2 g - T = m_2 a$$

$$T = m_2 g - m_2 a = (4.4)(9.8) - (4.4)(3.6)$$

$$T = 27.3 \text{ N}$$

9601

40.

A 1.5 kg block slides from rest down a ramp inclined at 20° from the horizontal. The graph below shows how the displacement, d , of the block from the top of the ramp varies with the square of the time, t , after release.

from rest
so $v_i = 0$

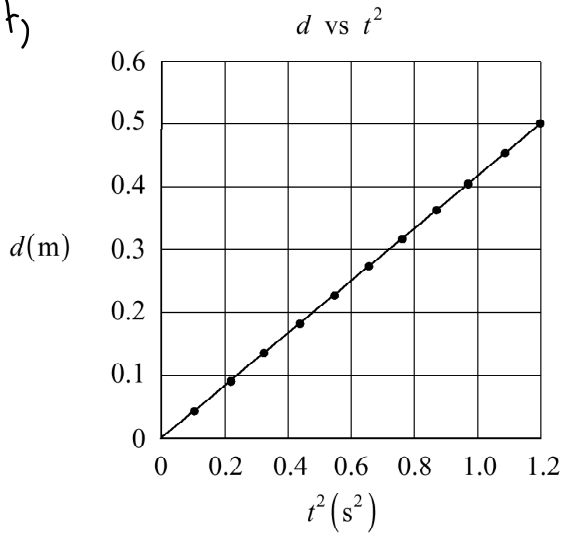

$$d = v_i t + \frac{1}{2} a t^2$$

$$d = \frac{1}{2} a t^2$$

$$\frac{d}{t^2} = \text{slope} = \frac{1}{2} a$$

a) What is the block's acceleration down the ramp?

(5 marks)

$$\frac{d}{t^2} = \text{slope} = \frac{1}{2} a$$

$$\frac{1}{2} a = .417$$

$$\text{slope} = \frac{\text{rise}}{\text{run}} = \frac{.5 - 0}{1.2 - 0} = .417$$

$$a = .833 \text{ m/s}^2$$

b) What is the coefficient of friction between the block and the ramp?

(7 marks)

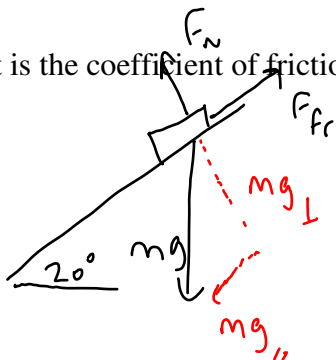

$$m g_{\parallel} - F_{fr} = m a$$

$$m g_{\parallel} - \mu F_N = m a$$

$$m g_{\parallel} - \mu m g_{\perp} = m a$$

$$g \sin 20 - \mu g \cos 20 = a$$

$$\frac{g \sin 20 - a}{g \cos 20} = \mu = \frac{9.8 \sin 20 - .833}{9.8 \cos 20}$$

23

$$\mu = .27$$

Answers:

1. b
2. b
3. b
4. c
5. a
6. d
7. a) see my solution b) $m=16 \text{ kg}$
8. a
9. b
10. a) 50.3 N b) 26.2 N c) 2.1 m/s^2
11. a
12. a) 1.8 m/s^2 b) 13.3 kg
13. b
14. b
15. d
16. b
17. 1.7 m/s^2
18. a
19. b
20. c
21. b
22. d
23. a
24. a) see my key b) 7.3 m/s^2
25. c
26. a) see my key b) 5.7 m/s^2
27. c
28. d
29. b
30. c
31. a
32. d
33. b
34. d
35. b) 3.24 m/s^2 c) $4.76 \times 10^3 \text{ N}$
36. 4.6 m/s^2
37. $7.0 \times 10^2 \text{ m}$
38. a) 0.249 b) 3.27 m/s^2
39. a) 3.6 m/s^2 b) 27.3 N
40. a) 0.83 m/s^2 b) 0.27